

DHI-HY-SA5MB

Mains Smoke Alarm with Replaceable 9V Battery Back-up



- Split-spectrum sensor technology
- Built-in replaceable 9V battery back-up
- Hardwire interconnection up to 24 units
- Wireless interconnected with maximum of 24 devices, compatible with WisuLink wireless interconnected module
- Test and silence features in the central push button
- Loud sound output over 85 dB(A) at 3 meters
- Silenced by a working infrared remote controller

System Overview

Mains Powered Smoke Alarm is specifically designed to continuously monitor smoke concentration. Adopting advanced split-spectrum photoelectric chamber and a built-in high-volume buzzer, it responds quickly and becomes highly sensitive with stable performance and low false alarm. Once the surrounding smoke concentration reaches the alarm value, it will promptly send out visual and audible alarm signal to remind the user to take immediate measures. Smoke alarm can be interconnected via a hardwired or wireless system (using optional WisuLink wireless interconnected module). Once one device triggers an alarm, the alarm signal will be pushed to every alarm in the interconnected network and they will raise the alarm in unison.

Scene

Application scenarios include household or similar residential applications such as family home or apartment.

Technical Specification

Working Principle

Collection Type	Smoke
Sampling Period	10 s
Sensor Type	Photoelectric
Alarm	
Alarm Type	Smoke alarm, fault warning, low battery warning
Alarm Response Threshold	0.2dB/m-0.3dB/m
Alarm Volume	≥ 85dB (A) at 3 m (9.84 ft)

Technical Specification

Alarm Mode	Visual and audible alarm
Silencing Function	Yes
Silence Duration	9 min
Silence by IR Remotes	Support
Basic Parameters	
Indicator Light	Alarm, fault and operation indicator
LED Instructions	Standby: Green indicator remains lit Alarm: Red indicator flashes once per second Sensor fault: Yellow indicator flashes twice per minute Low battery backup fault: Yellow indicator flashes once per minute
Maximum Number of Connected Units	24 hardwire interconnected / 24 wirelessly interconnected with WisuLink wireless interconnected module
Power Supply	
Power Source	AC 100V- 250V, 50/60Hz
Battery Back-up	Replaceable 9V alkaline battery
Battery Life	1 year
Operating Ambient	
Operating Environment	Indoor
Operating Temperature	-10°C to +55°C (+14°F to +131°F)
Operating Humidity	≤95% RH (non condensing)
Appearance	
Color	White
Casing	PC+ABS

Dimensions	φ148.6mm × H55.5mm (φ5.85" × H2.19")
Weight	330 g
Installation	Ceiling Mount
Certification	
Certifications	CE, UKCA, RCM, PSTI, BSI, Activfire
Compliance Standard	EN 14604:2005+AC:2008 and AS 3786:2014

Ordering Information

Type	Part Number	Description
Smoke Alarm	DHI-HY-SA5MB	Mains Smoke Alarm with 9V Alkaline Battery Back-up

Installation

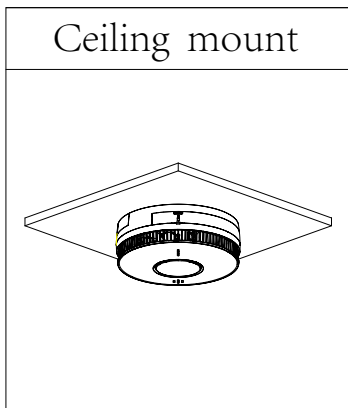

Dimensions (mm/inch)

