

DH-PFA139-G

Junction Box



- Built of aluminum alloy.
- Matched with particular cameras, beautiful and elegant designed.



Series Overview

The Junction Box is beautifully designed and highly convenient. Cables can be organized in it and there are outlets at the bottom and side of the box, making it easy to install and use.

Scene

Ideal for mounting cameras, it works in temperatures ranging from -40°C to $+60^{\circ}\text{C}$ (-40°F to $+140^{\circ}\text{F}$) and in environments with relative humidity of less than 90%.

Technical Specification

Structure

Casing Material	Aluminum alloy
Product Dimensions	$\Phi 109.9\text{ mm} \times 27.0\text{ mm}$ ($\Phi 4.33" \times 1.06"$)
Appearance Color	Gray
Net Weight	0.17 kg (0.37 lb)
Gross Weight	0.23 kg (0.51 lb)
Load bearing	1.0 kg (2.20 lb)
Installation	Junction mount
Screw Thread Type	G1/2
Packaging Dimensions	$119\text{ mm} \times 49\text{ mm} \times 124\text{ mm}$ ($4.69" \times 1.93" \times 4.88"$) (L x W x H)
Applicable Model	Please see "Camera Accessories Selection"

Environment

Operating Temperature	-40°C to $+60^{\circ}\text{C}$ (-40°F to $+140^{\circ}\text{F}$)
Operating Humidity	< 90% (RH)
Storage Temperature	-40°C to $+60^{\circ}\text{C}$ (-40°F to $+140^{\circ}\text{F}$)
Storage Humidity	10%–90% (RH)
Anti-corrosion Level	Basic Protection

Ordering Information

Type	Model	Description
Camera Mount	DH-PFA139-G	Junction Box

Installation

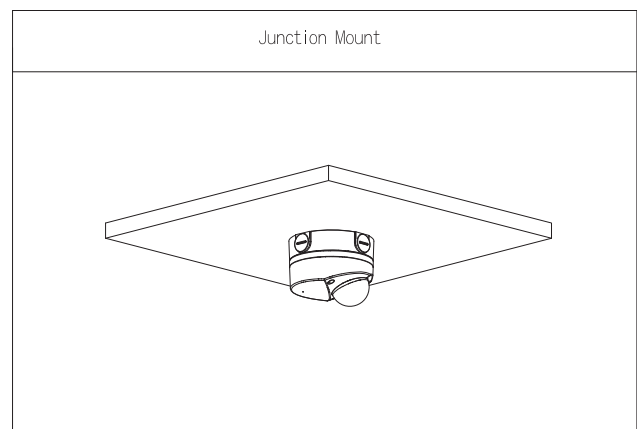

Dimensions (mm[inch])

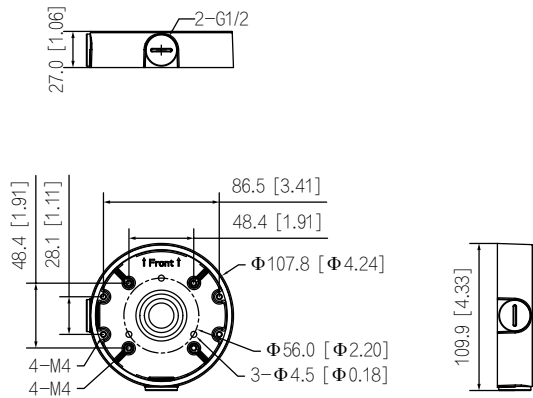

Package Information

- Junction box × 1
- ST4×25 screw × 3
- Plastic expansion bolt × 3
- M4×10 screw × 4
- S3.0 wrench × 1
- Water joint × 1